

A**Application**

Series D41 hydraulic directional control valves are high performance, solenoid controlled, pilot operated, 2-stage, 4-way valves. They are available in 2 or 3 position styles and are manifold mounted. These valves conform to NFPA's D07, CETOP 7 mounting patterns.

Operation

Series D41 directional valves consist of a 5-chamber style main body, a case hardened sliding spool, and a pilot valve or oil pilot operator.

Features

- Easy access mounting bolts.
- 345 Bar (5000 PSI) pressure rating.
- Flows to 300 LPM (79.4 GPM) depending on spool.
- Choice of three operator styles.
- Rugged four land spools.
- Low pressure drop.
- Phosphate finish.

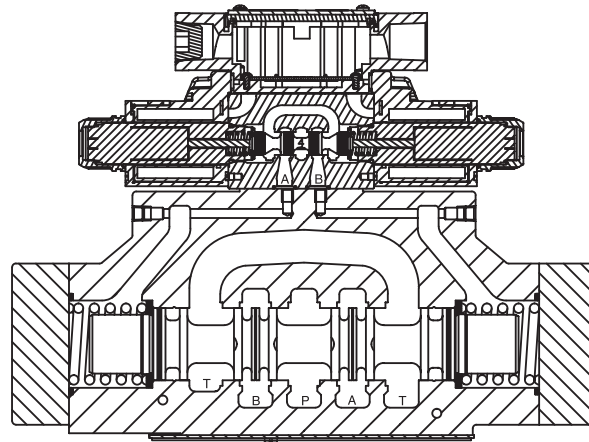

D41VW Solenoid Operated Plug-In Conduit Box

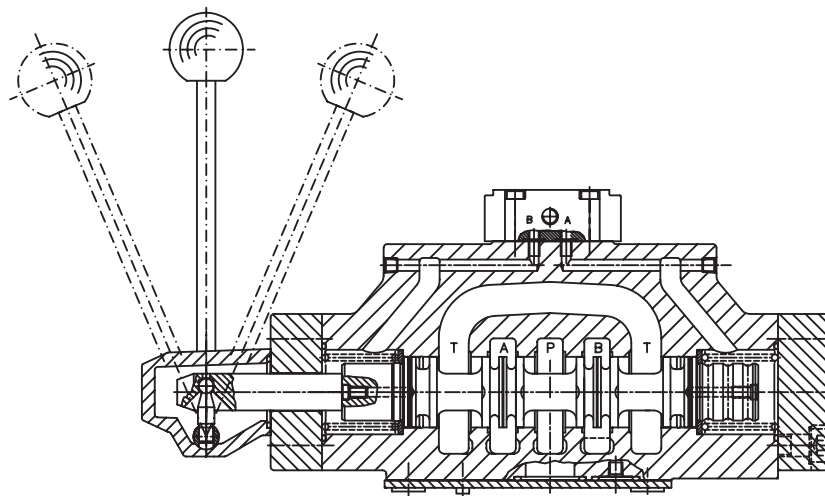

D4L Lever Operated

General Description

Series D41VW valves are piloted by a D1VW valve. The valves can be ordered with position control.

The minimum pilot pressure must be ensured for all operating conditions of the directional valve.

Additionally spools with a P to T connection in the de-energized position need an external pressure supply (external inlet) or an integral check valve.

Features

- **World design** – Available worldwide.
- **Mounting bolts below center line of spool** – Minimizes spool binding.
- **Five chamber style** – Eliminates pressure spikes in tubes, increasing valve life.
- **High pressure and flow ratings** – Increased performance options in a compact valve.

Dimensions

Inch equivalents for millimeter dimensions are shown in (**)

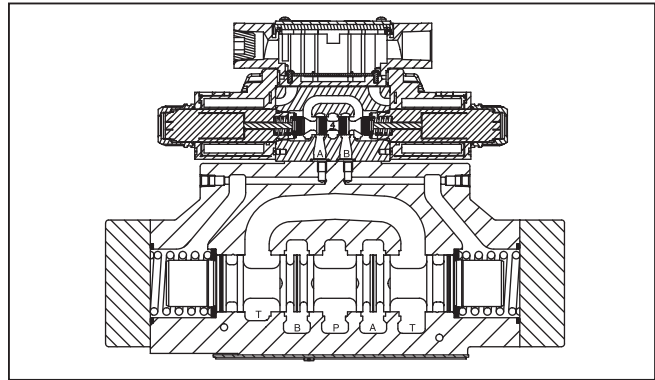
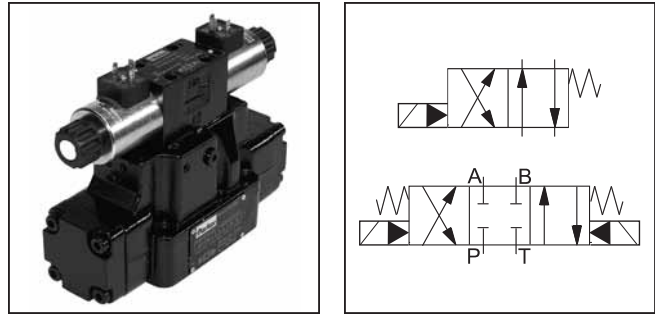

A

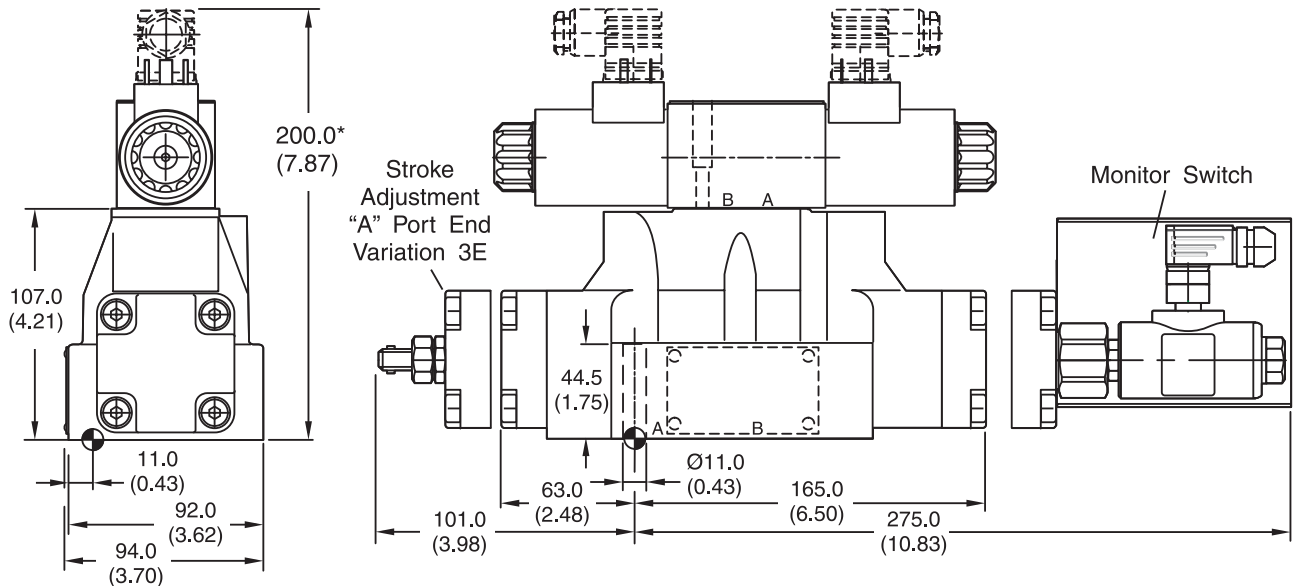

* Please add for each sandwich plate +40mm (1.58") (pressure reducing valve, pilot choke valve meter-in/-out).

Surface Finish	Kit	Kit	Kit	Seal Kit
$\sqrt{R_{max}6.3}$ $\square 0.01/100$	BK320	4x M10x60 2x M6x55 DIN 912 12.9	63 Nm (46.5 lb.-ft.) 13.2 Nm (9.7 lb.-ft.) ±15%	Nitrile: SK-D41VW-N-91 Fluorocarbon: SK-D41VW-V-91

The space necessary to remove the plug per DIN 43650, design type AF is at least 15 mm.

The torque for the screw M3 of the plug has to be 0.5 to 0.6 Nm.

A

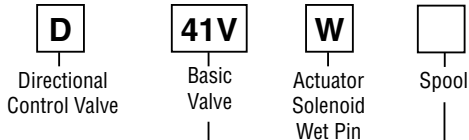

NFPA D07,
 CETOP 7
 DIN NG16



Code	Description	
1	Internal Pilot	External Drain
2	External Pilot	External Drain
3	Internal Pilot w/ Check	Internal Drain
4	Internal Pilot	Internal Drain
5	External Pilot	Internal Drain
6	Internal Pilot w/ Check	Internal Drain

* Not available with 002, 007, 009, 054 spools.

3-Position Spools	
Code	Spool Type
	a 0 b
001	
002	
003	
004	
005	
006	
007	
009	
011	
014	
015	
016	
021	
022	
054	
081	
082	

2-Position Spools	
Code	Spool Type
	a b
020	
026	
030	

3-Position Spools		
Code	All 3-Position Spools	
C		3 positions. Spring offset in position "0". Operated in position "a" or "b".
	Standard	Spool Type 009
E	 Operated in position "a".	 Operated in position "b".
F	 Spring offset in position "b".	 Spring offset in position "a".
K	 Operated in position "b".	 Operated in position "a".
M	 Spring offset in position "a".	 Spring offset in position "b".
R	 No center in offset position.	 No center in offset position.
S	 No center in offset position.	 No center in offset position.

2-Position Spools		
Code	Spool Position	
B		Spring offset in position "b". Operated in position "a".
D		Detent, operated in position "a" or "b". No center or offset position.
H		Spring offset in position "a". Operated in position "b".

Weight:
 Single Solenoid: 9.7 kg (21.4 lbs.)
 Double Solenoid: 10.3 kg (22.7 lbs.)

Bold: Designates Tier I products and options.

Non-Bold: Designates Tier II products and options. These products will have longer lead times.

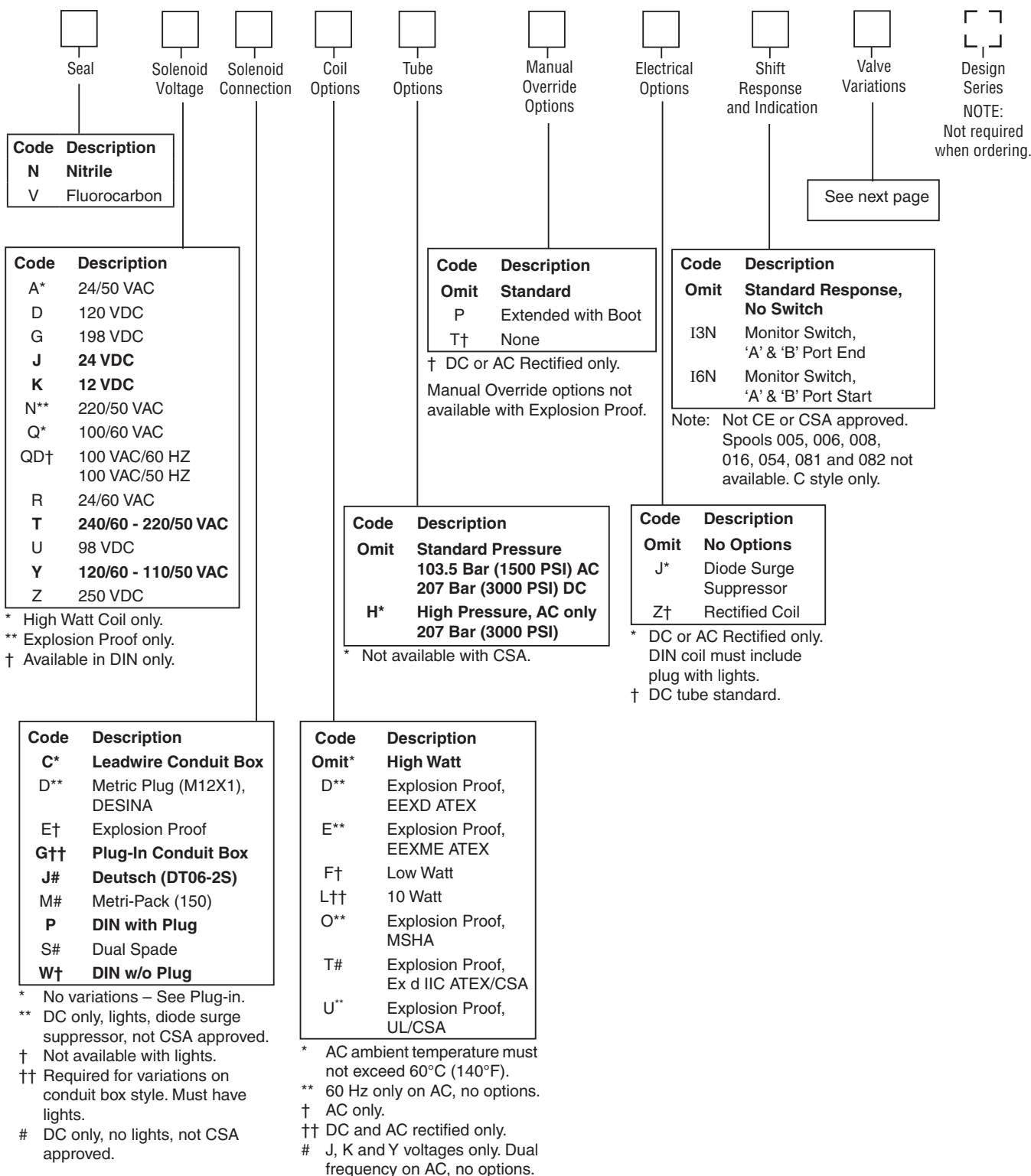

Bold: Designates Tier I products and options.

Non-Bold: Designates Tier II products and options. These products will have longer lead times.

Valve Variations

A

Code	Description
5*	Signal Lights – Standard Signal Lights – Hirsch. (DIN with Plug)
7B**	Manaplug – Brad Harrison (12x1) Micro with Lights
56**	Manaplug (Mini) with Lights
1C**	Manaplug (Mini) Single Sol. 5-pin, with Lights
1D**	Manaplug (Micro) Single Sol. 5-pin, with Lights
1G**	Manaplug (Mini) Single Sol. 5-pin, with Stroke Adjust 'A' & 'B' End and Lights
1H**	Manaplug (Micro) Single Sol. 5-pin, with Stroke Adjust 'A' & 'B' End and Lights
1M**	Manaplug Opposite Normal
1R	Stroke Adjust 'A' & 'B' End with Pilot Choke Meter In
3A	Pilot Choke Meter Out
3B	Pilot Choke Meter In
3C	Pilot Pressure Reducer
3D	Stroke Adjust 'B' End
3E	Stroke Adjust 'A' End
3F	Stroke Adjust 'A' & 'B' End
3G*	Pilot Choke Meter Out with Lights
3H*	Pilot Choke Meter In with Lights
3J*	Pilot Pressure Reducer with Lights
3K	Pilot Choke Meter Out with Stroke Adjust 'A' & 'B' End
3L**	Pilot Choke Meter Out, Stroke Adjust 'A' & 'B' End with Lights and Manaplug — Brad Harrison Mini
3M	Pilot Choke Meter Out, Pilot Pressure Reducer, Stroke Adjust 'A' & 'B' End
3R	Pilot Choke Meter Out & Pilot Pressure Reducer
3S**	Lights and 5-pin Mini Manaplug with Pilot Choke
7Y**	M12x1 Manaplug (4-pin), Special Wiring, and Lights

* DESINA, plug-in conduit box, and DIN with plug styles only.

** Must have plug-in style conduit box.

Bold: Designates Tier I products and options.

Non-bold: Designates Tier II products and options. These products will have longer lead times.

Solenoid Ratings

Insulation System	Class F
Allowable Deviation from rated voltage	-15% to +10% for DC and AC rectified coils -5% to +5% for AC Coils
Armature	Wet pin type
CSA File Number	LR60407
Environmental Capability	DC Solenoids meet NEMA 4 and IP67 when properly wired and installed. Contact HVD for AC coil applications.

Explosion Proof Solenoid Ratings*

U.L. & CSA (EU)	Class I, Div 1 & 2, Groups C & D Class II, Div 1 & 2, Groups E, F & G As defined by the N.E.C.
MSHA (EO)	Complies with 30CFR, Part 18
ATEX (ED)	Complies with ATEX requirements for: Exd, Group IIB; EN50014: 1999+ Amds. 1 & 2, EN50018: 2000
ATEX & CSA/US (ET)	Complies with ATEX EN60079-0, EN60079-1 Ex d IIC; CSA/US Ex d IIC, AEx d IIC for Class I, Zone 1, UL1203, UL1604, CSA E61241,1 Class II, Div 1



* Allowable Voltage Deviation ±10%.
 Note that Explosion Proof AC coils are single frequency only.

Code		Voltage	In Rush Amps Amperage	In Rush VA	Holding Amps @ 3MM	Watts	Resistance
Voltage Code	Power Code						
D	L	120 VDC	N/A	N/A	0.09 Amps	10 W	1584.00 ohms
D	Omit	120 VDC	N/A	N/A	0.26 Amps	30 W	528.00 ohms
G	Omit	198 VDC	N/A	N/A	0.15 Amps	30 W	1306.80 ohms
J	L	24 VDC	N/A	N/A	0.44 Amps	10 W	51.89 ohms
J	Omit	24 VDC	N/A	N/A	1.32 Amps	30 W	17.27 ohms
K	L	12 VDC	N/A	N/A	0.88 Amps	10 W	12.97 ohms
K	Omit	12 VDC	N/A	N/A	2.64 Amps	30 W	4.32 ohms
L	L	6 VDC	N/A	N/A	1.67 Amps	10 W	3.59 ohms
L	Omit	6 VDC	N/A	N/A	5.00 Amps	30 W	1.20 ohms
Q	Omit	100 VAC / 60 Hz	2.05 Amps	170 VA	0.77 Amps	30 W	19.24 ohms
QD	F	100 VAC / 60 Hz	1.35 Amps	135 VA	0.41 Amps	18 W	31.20 ohms
QD	F	100 VAC / 50 Hz	1.50 Amps	150 VA	0.57 Amps	24 W	31.20 ohms
R	F	24/60 VAC, Low Watt	6.67 Amps	160 VA	2.20 Amps	23 W	1.52 ohms
T	Omit	240/60 VAC	0.83 Amps	199 VA	0.30 Amps	30 W	120.40 ohms
T	Omit	220/50 VAC	0.87 Amps	191 VA	0.34 Amps	30 W	120.40 ohms
T	F	240/60 VAC, Low Watt	0.70 Amps	168 VA	0.22 Amps	21 W	145.00 ohms
T	F	220/50 VAC, Low Watt	0.75 Amps	165 VA	0.26 Amps	23 W	145.00 ohms
U	L	98 VDC	N/A	N/A	0.10 Amps	10 W	960.00 ohms
U	Omit	98 VDC	N/A	N/A	0.31 Amps	30W	288.00 ohms
Y	Omit	120/60 VAC	1.7 Amps	204 VA	0.60 Amps	30 W	28.20 ohms
Y	Omit	110/50 VAC	1.7 Amps	187 VA	0.68 Amps	30 W	28.20 ohms
Y	F	120/60 VAC, Low Watt	1.40 Amps	168 VA	0.42 Amps	21 W	36.50 ohms
Y	F	110/50 VAC, Low Watt	1.50 Amps	165 VA	0.50 Amps	23 W	36.50 ohms
Z	L	250 VDC	N/A	N/A	0.04 Amps	10 W	6875.00 ohms
Z	Omit	250 VDC	N/A	N/A	0.13 Amps	30 W	1889.64 ohms
Explosion Proof Solenoids							
R		24/60 VAC	7.63 Amps	183 VA	2.85 Amps	27 W	1.99 ohms
T		240/60 VAC	0.76 Amps	183 VA	0.29 Amps	27 W	1.34 ohms
N		220/50 VAC	0.77 Amps	169 VA	0.31 Amps	27 W	1.38 ohms
Y		120/60 VAC	1.60 Amps	192 VA	0.58 Amps	27 W	33.50 ohms
P		110/50 VAC	1.47 Amps	162 VA	0.57 Amps	27 W	34.70 ohms
K		12 VDC	N/A	N/A	2.75 Amps	33 W	4.36 ohms
J		24 VDC	N/A	N/A	1.38 Amps	33 W	17.33 ohms
"ET" Explosion Proof Solenoids							
K		12 VDC	N/A	N/A	1.00 Amps	12 W	12.00 ohms
J		24 VDC	N/A	N/A	1.00 Amps	13 W	44.30 ohms
Y		120/60-50 VAC	N/A	N/A	0.16 Amps	17 W	667.00 ohms

A

General		
Design	Directional Spool Valve	
Actuation	Solenoid	
Size	NG16	
Mounting Interface	DIN 24340 A16 / ISO 4401 / NFPA D07 / CETOP RP 121-H	
Mounting Position	Unrestricted, preferably horizontal	
Ambient Temperature	[°C] -25...+50; (-13°F...+122°F) (without inductive position control) [°C] 0...+50; (+32°F...+122°F) (with inductive position control)	
MTTF _D Value	[years] 75	
Hydraulic		
Maximum Operating Pressure	Pilot drain internal: P, A, B, X 350 Bar (5075 PSI); T, Y 105 Bar (1523 PSI) Pilot drain external: P, A, B, T, X 350 Bar (5075 PSI); Y 105 Bar (1523 PSI) 10 Watt 207 Bar (3000 PSI)	
Fluid	Hydraulic oil in accordance with DIN 51524 / 51525	
Fluid Temperature	[°C] -25 ... +70 (-13°F...+158°F)	
Viscosity Permitted	[cSt]/[mm ² /s] 2.8...400 (13...1854 SSU)	
Recommended	[cSt]/[mm ² /s] 30...80 (139...371 SSU)	
Filtration	ISO 4406 (1999); 18/16/13 (meet NAS 1638: 7)	
Flow Maximum	300 LPM (79.4 GPM)	
Leakage at 350 Bar (per flow path)	[ml/min] up to 200 (0.05 GPM) (depending on spool)	
Operating Pressure Integral Check Valve	See p/Q Diagram	
Minimum Pilot Supply Pressure	5 Bar (73 PSI)	
Static / Dynamic		
Step Response at 85%	Energized	De-energized
DC Solenoids		
Pilot Pressure		
50 Bar [ms]	95	65
100 Bar [ms]	75	65
250 Bar & 350 Bar [ms]	60	65
AC Solenoids		
Pilot Pressure		
50 Bar [ms]	75	55
100 Bar [ms]	65	55
250 Bar & 350 Bar [ms]	40	55



Position Control M12x1

Protection Class		IP 65 in accordance with EN 60529 (plugged and mounted)
Ambient Temperature	[°C]	0...+50; (+32°F...122°F)
Supply Voltage / Ripple	[V]	18...42 ±10%
Current Consumption without Load	[mA]	≤ 30
Max. Output Current per Channel, Ohmic	[mA]	400
Min. Output Load per Channel, Ohmic [kOhm]		100
Max. Output Drop at 0.2A	[V]	≤ 1.1
Max. Output Drop at 0.4A	[V]	≤ 1.6
EMC		EN50081-1 / EN50082-2
Max. Tolerance Ambient Field Strength	[A/m]	<1200
Min. Distance to Next AC Solenoid	[m]	>0.1
Interface		M12x1 per IEC 61076-2-101
Wiring Minimum	[mm²]	5 x 0.25 brad shield recommended
Wiring Length Maximum	[m]	50 (164 ft.) recommended

M12 Pin Assignment

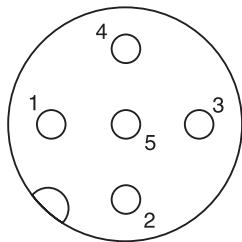

- 1 + Supply 18...42V
- 2 Out B: normally closed
- 3 0V
- 4 Out A: normally open
- 5 Earth ground

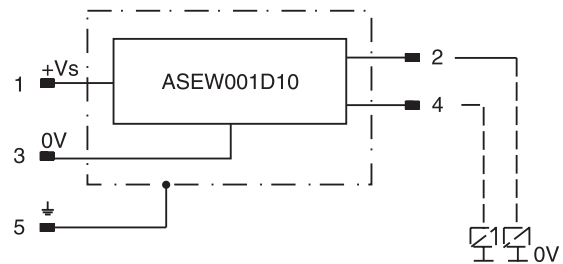

Definitions

Start position monitored:

The valve is de-energized. The inductive switch gives a signal at the moment (below 15% spool stroke) when the spool leaves the spring offset position.

End position monitored:

The inductive switch gives a signal before the end position is reached. (above 85% spool stroke).

Delivery includes plug M12 x 1 (order no.: 5004109).

Performance Curves

A

The flow curve diagram shows the flow versus pressure drop curves for all spool types. The relevant curve number for each spool type, operating position and flow direction is given in the table below.

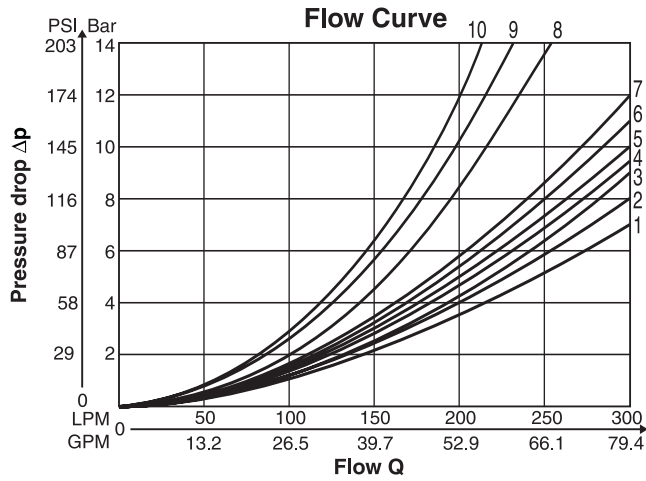

All characteristic curves measured with HLP46 at 50°C.

Spool Code	Curve Number				
	P-A	P-B	P-T	A-T	B-T
001	1	1	—	4	5
002	1	2	6	4	6
003	1	2	—	5	6
004	1	1	—	5	5
005	2	2	—	3	5
006	1	2	—	3	6
007	1	1	6	4	5
009	2	9	8	7	10
011	1	1	—	4	5
014	1	1	6	4	5
015	1	2	—	4	6
016	2	2	—	3	5
020	3	5	—	3	5
021	2	8	—	2	—
022	8	2	—	—	3
026	3	5	—	—	—
030	2	3	—	6	7
054	2	3	—	6	7

Integral Check Valve in the P port

Mounting an integral check valve in the P port is necessary to build up pilot pressure for valves with P to T connection and internal pilot oil supply. The pressure difference at the integral check valve (see performance curves) is to be added to all flow curves of the P-port of the main valve.

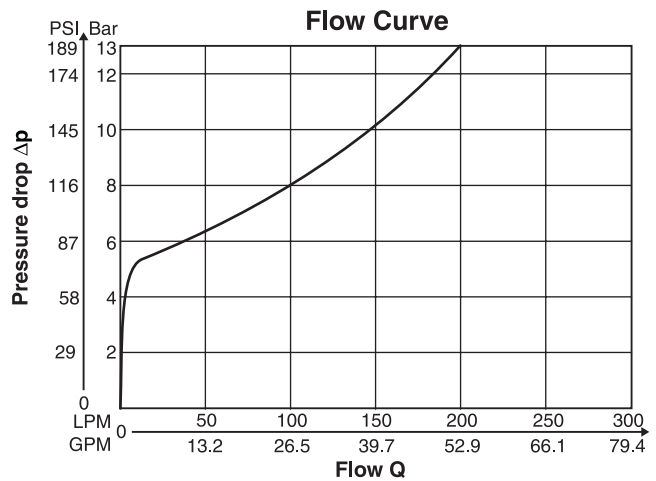

Pilot Oil Inlet (Supply) and Outlet (Drain)

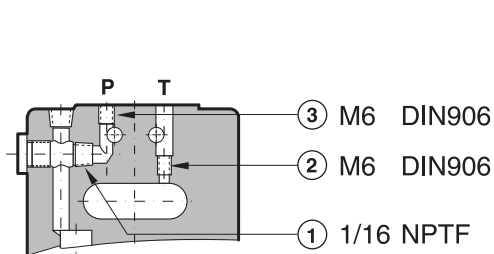

○ open, ● closed

Pilot Oil		1	2	3
Inlet	Outlet			
internal	external	○	●	Orifice Ø1.5
external	external	●	●	Orifice Ø1.5
internal	internal	○	○	Orifice Ø1.5
external	internal	●	○	Orifice Ø1.5

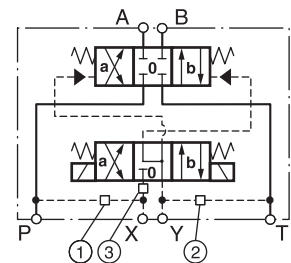

All orifice sizes for standard valves



Manaplug (Options 6, 56, 1A & 1C)

- Interface – Brad Harrison Plug
- 3-Pin for Single Solenoid
 - 5-Pin for Double Solenoid

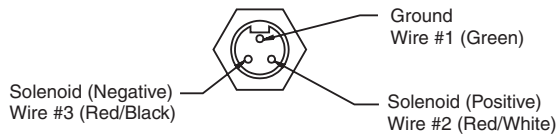

3-Pin Manaplug (Mini) with Lights

Single Solenoid Valves – Installed Opposite Side of Solenoid

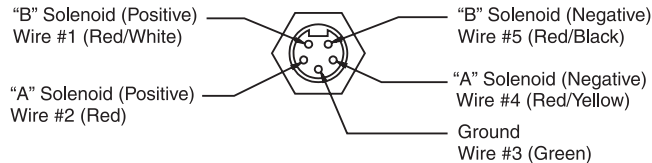

5-Pin Manaplug (Mini) with Lights

Single Solenoid Valves – Installed Opposite Side of Solenoid
Double Solenoid Valves – Installed Over "A" Solenoid
("A" and "B" Solenoids Reversed for #8 and #9 Spools)

Micro Connector Options (7A, 7B, 1B & 1D)

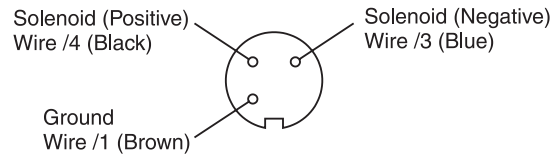

3-Pin Manaplug (Micro) with Lights

Single Solenoid Valves – Installed Opposite Side of Solenoid

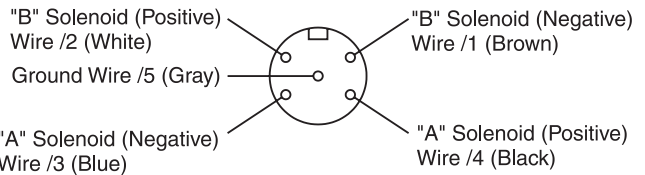

5-Pin Manaplug (Micro) with Lights

Single Solenoid Valves – Installed Opposite Side of Solenoid
Double Solenoid Valves – Installed Over "A" Solenoid
("A" and "B" Solenoids Reversed for #8 and #9 Spools)

Pins are as seen on valve (male pin connectors)

Manaplug – Electrical Mini Plug

- EP336-30** 3 Pin Plug
- EP316-30** 5 Pin Plug (Double Solenoid)
- EP31A-30** 5 Pin Plug (Single Solenoid)

Manaplug – Electrical Micro Plug

- EP337-30** 3 Pin Plug
- EP317-30** 5 Pin Plug (Double Solenoid)
- EP31B-30** 5 Pin Plug (Single Solenoid)

Conduit Box Option C

- No Wiring Options Available

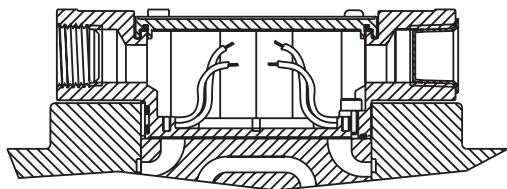

Signal Lights (Option 5) — Plug-in Only

- LED Interface
- Meets Nema 4/IP67

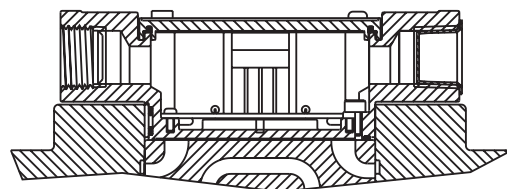

**Hirschmann Plug with Lights (Option P5)
ISO 4400/DIN 43650 Form "A"**

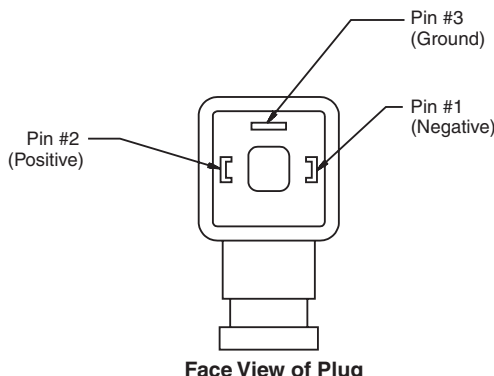

Face View of Plug

**DESINA Connector (Option D)
M12 pin assignment
Standard**

- 1 = Not used
- 2 = Not used
- 3 = 0V
- 4 = Signal (24 V)
- 5 = Earth Ground

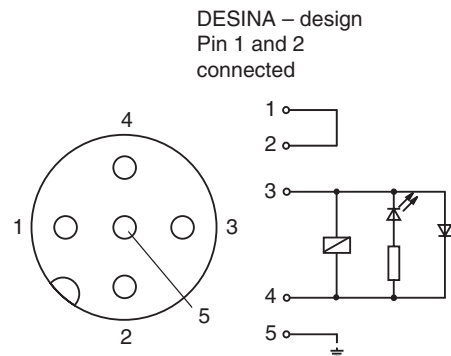

Pins are as seen on valve (male pin connectors)

General Description

A

Series D4L valves are 5 chamber, directional control valves and are available in 2 or 3-position styles. They are operated by a hand lever which is directly connected to the spool.

The hand lever can be located either on the A or B side. Spring offset and detent designs are available.

Features

- Low force required to shift spool.
- Hardened spools provide long life.
- Low pressure drop design.

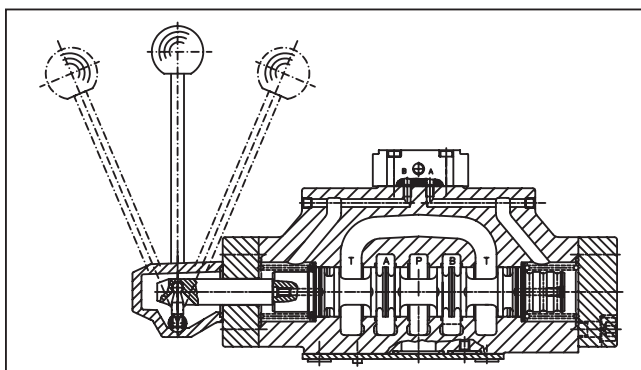
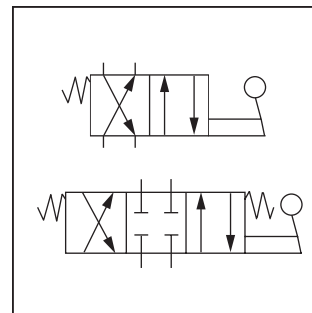
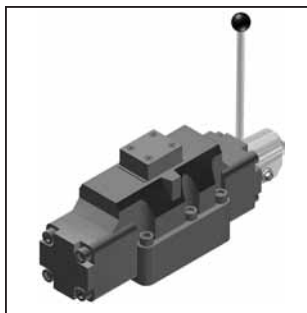

Specifications

General		
Design		Directional spool valve
Actuation		Lever
Size		NG16
Mounting interface		DIN 24340 A16, ISO 4401, NFPA D07, CETOP RP 121-H
Mounting Position		Unrestricted, preferably horizontal
Ambient Temperature	[°C]	-25...+50; (-13°F...+122°F)
Hydraulic		
Maximum Operating Pressure		External Drain: P, A B, T 350 Bar (5075 PSI); X, Y 10 Bar (145 PSI) Internal Drain: P, A B 350 Bar (5075 PSI); T, X, Y 10 Bar (145 PSI)
Fluid		Hydraulic oil in accordance with DIN 51524 / 51525
Fluid Temperature	[°C]	-25 ... +70; (-13°F...+158°F)
Viscosity Permitted	[cSt] / [mm²/s]	2.8...400 (13...1854 SSU)
Recommended	[cSt] / [mm²/s]	30...80 (139...371 SSU)
Filtration		ISO 4406 (1999); 18/16/13 (meet NAS 1638: 7)
Maximum Flow		300 LPM (79.4 GPM)
Leakage at 350 Bar (per flow path)	[ml/min]	up to 200 (0.05 GPM) (depending on spool)



D
 Directional Control Valve

4
 Basic Valve
 NFPA D07,
 CETOP 7
 DIN NG16

Actuator

Spool

Style

Pilot Supply and Drain

Seal

Design Series
 NOTE:
 Not required when ordering.

Code	Actuation
L	Lever Side B
LB	Lever Side A

Code	Description
2*	External Pilot External Drain
5**	External Pilot Internal Drain

* Pressure T-port > 10 bar
 ** Pressure T-port < 10 bar

Code	Description
N	Nitrile
V	Fluorocarbon

3 Position Spools		
Code	Spool Type	
	a	0 b
1		
2		
3		
4		
6		
7		
9		
11		
14		
15		

2 Position Spools	
Code	Spool Type
	a b
20	
30	

3 Position Spools		
Code	All 3 Position Spools	
C		3 positions. Spring offset in position "0". Operated in position "a" or "b".
	Standard	Spool Type 9
E	 Operated in position "a".	 Operated in position "b".
F	 Operated in position "0".	 Operated in position "0".
K	 Operated in position "b".	 Operated in position "a".
M	 Operated in position "0".	 Operated in position "0".
N	 No center in offset position.	 No center in offset position.
R	 No center in offset position.	 No center in offset position.
S	 No center in offset position.	 No center in offset position.

2 Position Spools		
Code	Spool Position	
B		Spring offset in position "b". Operated in position "a".
D		Detent, operated in position "a" or "b". No center or offset position.
H		Spring offset in position "a". Operated in position "b".

Weight: 9.0 kg (19.8 lbs.)

Further spool types on request.



The flow curve diagram shows the flow versus pressure drop curves for all spool types. The relevant curve number for each spool type, operating position and flow direction is given in the table below.

A

Spool Code	Curve Number				
	P-A	P-B	P-T	A-T	B-T
1	1	1	–	4	5
2	1	2	6	4	6
3	1	2	–	5	6
4	1	1	–	5	5
6	1	2	–	3	6
7	1	1	6	4	5
9	2	9	8	7	10
11	1	1	–	4	5
14	1	1	6	5	4
15	2	1	–	6	5
20	3	5	–	3	5
30	2	3	–	6	7

All characteristic curves measured with HLP46 at 50°C.

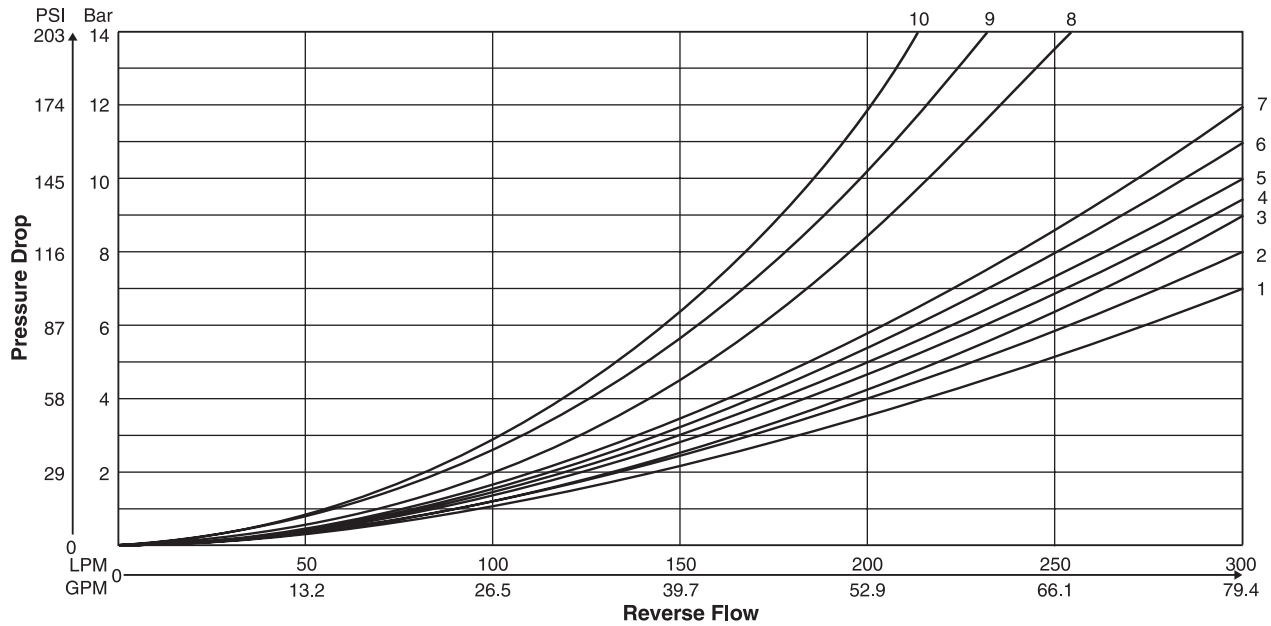

Inch equivalents for millimeter dimensions are shown in (**)

D4L

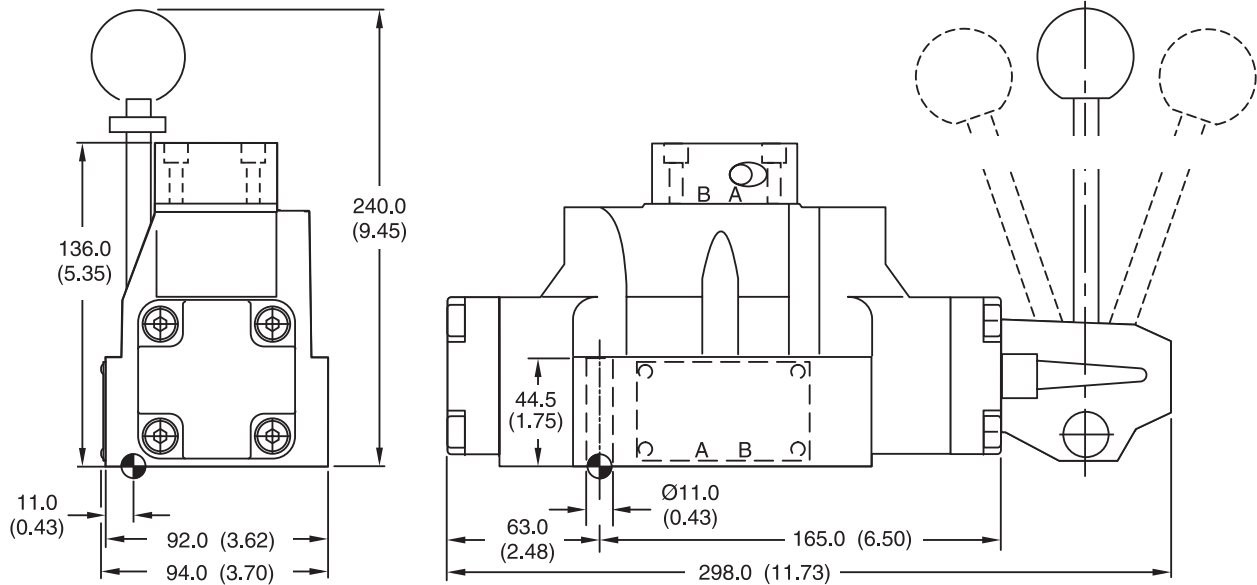

A

D4LB

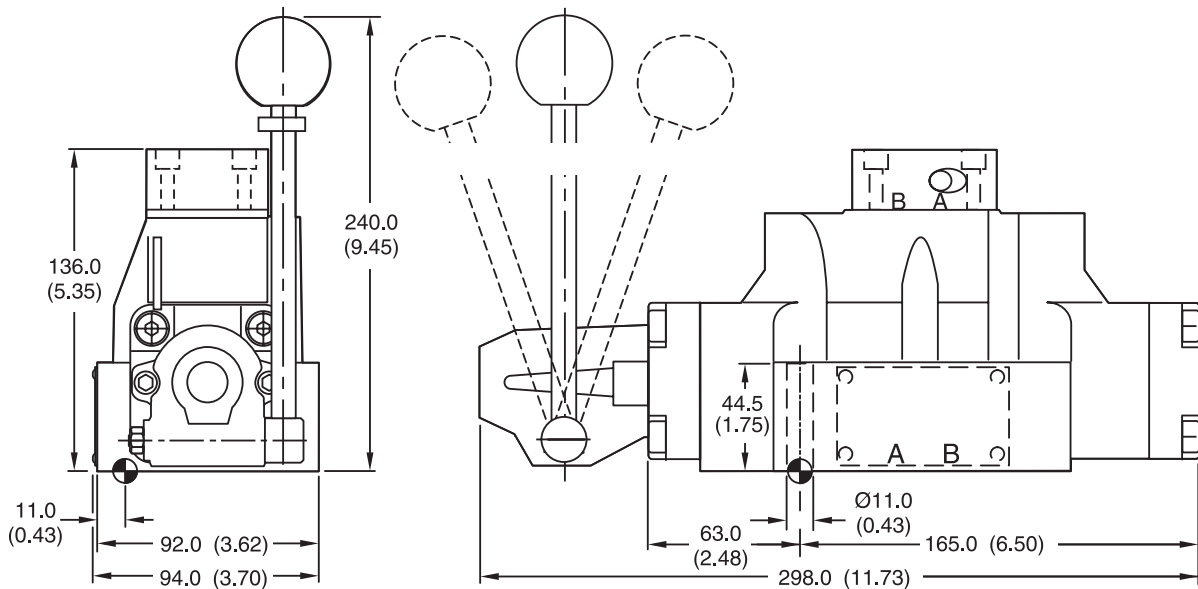

Surface Finish	Kit			Seal Kit
$\sqrt{R_{max} 6.3}$ $\square 0.01/100$	BK320	4x M10x60 2x M6x55 DIN 912 12.9	63 Nm (46.5 lb.-ft.) 13.2 Nm (9.7 lb.-ft.) ±15%	Nitrile: SK-D4LN60 Fluorocarbon: SK-D4LV60

General Description

A

Series D4P directional control valves are 5-chamber pilot operated valves. They are available in 2 or 3-position styles. These manifold mounted valves conform to NFPA's D07, CETOP 7 and NG16.

Features

- Low pressure drop design.
- Hardened spools for long life.

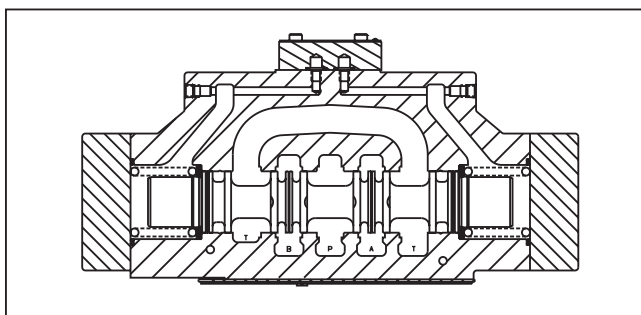
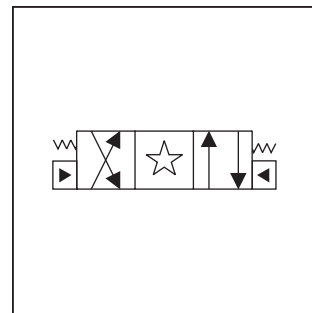

Specifications

General		
Design		Directional spool valve
Actuation		Hydraulic
Size		NG16
Mounting interface		DIN 24340 A16, ISO 4401, NFPA D07, CETOP RP 121-H
Mounting Position		Unrestricted, preferably horizontal
Ambient Temperature	[°C]	-25...+50 (-13°F...+122°F)
MTTF _D value		150 years
Hydraulic		
Maximum Operating Pressure		External Drain: P, A B, T 350 Bar (5075 PSI); X, Y 350 Bar (5075 PSI)
Fluid		Hydraulic oil in accordance with DIN 51524 / 51525
Fluid Temperature	[°C]	-25 ... +70 (-13°F...+158°F)
Viscosity Permitted	[cSt] / [mm ² /s]	2.8...400 (13...1850 SSU)
Recommended	[cSt] / [mm ² /s]	30...80 (139...371 SSU)
Filtration		ISO 4406 (1999); 18/16/13 (meet NAS 1638: 7)
Maximum Flow		300 LPM (79.4 GPM)
Leakage at 350 Bar (per flow path)	[ml/min]	up to 200 (0.05 GPM) (depending on spool)
Pilot Supply Pressure	Minimum Maximum	5 Bar (73 PSI) 350 Bar (5075 PSI)
Static / Dynamic		
Step Response		The response times depend on the pilot oil pressure and on the speed of the increase/ decrease of the pilot pressure.

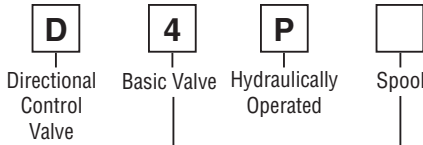

NFPA D07,
 CETOP 7
 DIN NG16

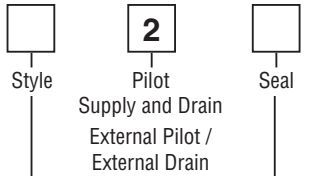

Code	Description
N	Nitrile
V	Fluorocarbon

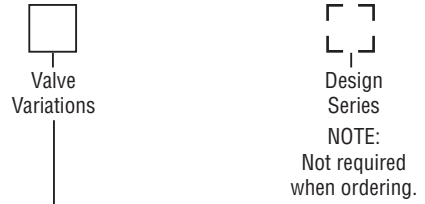

Code	Description	Code	Description
Omit	Standard Valve	9	Stroke Adjust A End
7	Pilot Choke, Meter-Out	60	Pilot Choke, Meter-In
8	Stroke adjust B End	89	Stroke Adjust A and B Ends

3 Position Spools	
Code	Spool Type
	a 0 b
1	
2	
3	
4	
5	
6	
7	
9	
11	
14	
15	
16	
21	
22	
54	
81	
82	

2 Position Spools	
Code	Spool Type
	a b
20	
26	
30	

3 Position Spools		
Code	All 3 Position Spools	
C		3 positions. Spring offset in position "0". Operated in position "a" or "b".
	Standard	Spool Type 9
E		2 positions. Spring offset in position "0". Operated in position "a".
		Operated in position "b".
F		2 positions. Spring offset in position "b". Operated in position "0".
		Spring offset in position "a".
K		2 positions. Operated in position "b". Spring offset in position "0".
		Operated in position "a".
M		2 positions. Spring offset in position "a". Operated in position "0".
		Spring offset in position "b".
R		2 positions, detent. No center in offset position. Operated in position "0" or "b".
		No center in offset position.
S		2 positions, detent. No center in offset position. Operated in position "0" or "a".
		No center in offset position.

2 Position Spools		
Code	Spool Position	
B		Spring offset in position "b". Operated in position "a".
D		Detent, operated in position "a" or "b". No center or offset position.
H		Spring offset in position "a". Operated in position "b".

Weight: 9.0 kg (19.8 lbs.)

Further spool types and position control on request.

The flow curve diagram shows the flow versus pressure drop curves for all spool types. The relevant curve number for each spool type, operating position and flow direction is given in the table below.

A

Spool Code	Curve Number				
	P-A	P-B	P-T	A-T	B-T
1	1	1	–	4	5
2	1	2	6	4	6
3	1	2	–	5	6
4	1	1	–	5	5
5	2	2	–	3	5
6	1	2	–	3	6
7	1	1	6	4	5
9	2	9	8	7	10
11	1	1	–	4	5
14	1	1	6	4	5
15	1	2	–	4	6
16	2	2	–	3	5
20	3	5	–	3	5
21	2	8	–	2	–
22	8	2	–	–	3
26	3	5	–	–	–
30	2	3	–	6	7
54	2	3	–	6	7

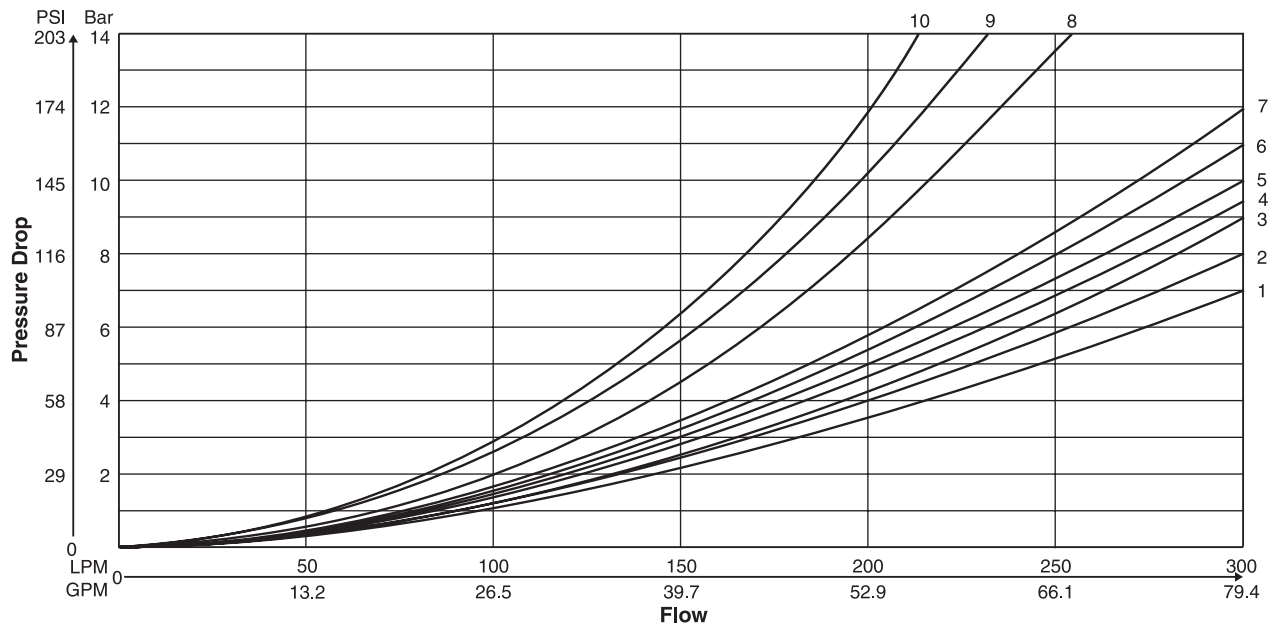

Inch equivalents for millimeter dimensions are shown in (**)

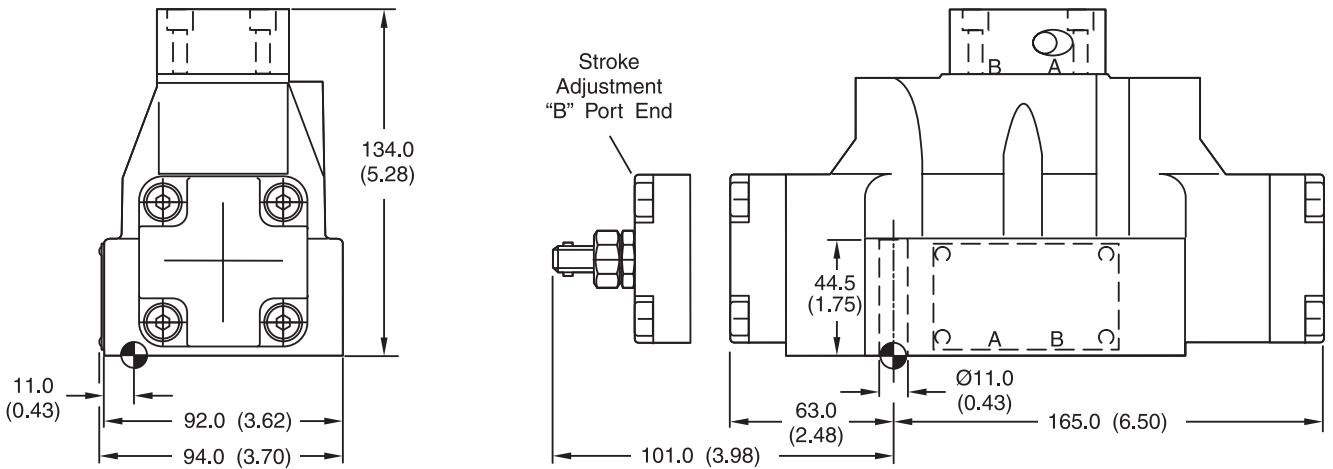

A

Surface Finish	Kit			Seal Kit
	BK320	4x M10x60 2x M6x55 DIN 912 12.9	63 Nm (46.5 lb.-ft.) 13.2 Nm (9.7 lb.-ft.) ±15%	Nitrile: SK-D41VW-N-91 Fluorocarbon: SK-D41VW-V-91

A

FOR MAXIMUM VALVE RELIABILITY, ADHERE TO THE FOLLOWING INSTALLATION INFORMATION.

The following is important installation information which applies to all directional control valves described in this catalog.

Mounting Position

Detent – Horizontal

Spring Offset – Unrestricted

Spring Centered – Unrestricted

Fluid Recommendations

Premium quality hydraulic oil with a viscosity range between 32-54 cSt. (150-250 SSU) At 38°C (100°F) is recommended. The absolute operating viscosity range is from 16-220 cSt. (80-1000 SSU). Oil should have maximum anti-wear properties and rust and oxidation treatment.

Fluids and Seals

Valves using synthetic, fire-resistant fluids require special seals. When phosphate esters or its blends are used, FLUOROCARBON seals are required. Water-glycol, water-in-oil emulsions and petroleum oil may be used with STANDARD seals.

Filtration

For maximum valve and system component life, the system should be protected from contamination at a level not to exceed 125 particles greater than 10 microns per milliliter of fluid (SAE class 4/ISO 16/13).

Silting

Silting can cause any sliding spool valve to stick and not spring return if held under pressure for long periods of time. The valve should be cycled periodically to prevent sticking.

Special Installations

Consult your Parker representative for any application requiring the following:

- Pressure above rating.
- Fluid other than those specified.
- Oil temperature above 71.1°C (160°F).
- Flow path other than normal.

Mounting Patterns

Series	NFPA	CETOP
D41V	D07	7

Torque Specifications

The recommended torque values for the bolts which mount the valve to the manifold or subplate are as follows:

63 Nm (46.5 ft-lbs) M10

13.2 Nm (9.7 ft-lbs) M6 1/4-20.



Tank and Drain Line Surges

If several valves are piped with a common tank or drain line, flow surges in the line may cause an unexpected spool shift. Detent style valves are most susceptible to this. Separate tank and drain lines should be piped in installations where line surges are expected.

Electrical Characteristics (Detented Spool)

Only a momentary energizing of the solenoid is necessary to shift and hold a detented spool. Minimum duration of the signal is 0.1 seconds for DC voltages. For AC voltages the response time is 0.06 seconds. Spool position will be held provided the spool centerline is in a horizontal plane, and not shock or vibration is present to displace the spool.

Electrical Failure or Loss of Pilot Pressure

Should electric power fail or loss of pilot pressure occur, spring offset and spring centered valves will shift to the spring held position. Detented valves will stay in the last position held before power failure. If main flow does not fail or stop at the same time power fails, machine actuators may continue to function in an undesirable manner or sequence.

Pilot/Drain Characteristics

Pilot Pressure:

5 to 345 Bar (73 to 5000 PSI)
 6.9 Bar (100 PSI) for spools 002, 007, 009 & 014

External: An oil source sufficient to maintain minimum pilot pressure must be connected to the “X” port of the main body. When using the external pilot variation, a 1/16” pipe plug must be present in the main body pilot passage. (For details see Technical pages.) This plug will be furnished in valves ordered with pilot code 2, 3, 5 or 6.

Internal: Flow is internally ported from the pressure port of the main valve body to the “P” port of the pilot valve. The pressure developed at the “P” port of the pilot valve must be 5.0 Bar (73 PSI) minimum at all times or 6.9 Bar (100 PSI) for spools 002, 007, 009 & 014.

Integral Check: Valves using internal pilot and internal drain with an open center spool (spools 2, 7 & 9) can be ordered with an integral check valve in the pressure port of the main valve codes 3 & 6. Pilot oil will be internally ported from the upstream side of this check to the “P” port of the pilot valve, ensuring sufficient pilot pressure. A 1/16” pipe plug will be present in the main body. The “X” port in the subplate must be plugged when using the integral check.

Pilot Valve Drain: Maximum pressure 102 Bar (1500 PSI) AC optional, 207 Bar (3000 PSI) DC standard.

External: When using an external drain, a M6 x 1 x 6mm long set screw must be present in the main body drain passage. (For details see Technical pages.) This plug will be furnished in valves ordered with drain code 1, 2 or 3.

Drain flow from the pilot valve is at the “Y” port of the main body and must be piped directly to tank. Maximum drain line pressure is 102 Bar (1500 PSI), AC optional, 207 Bar (3000 PSI) DC standard. Any drain line back pressure is additive to the pilot pressure requirement.

Internal: Drain flow from the pilot valve is internally connected to the main valve tank port. Tank and drain pressure are then identical so tank line pressure should not exceed 102 Bar (1500 PSI), AC optional, 207 Bar (3000 PSI) DC standard. Any tank line back pressure is also additive to the pilot pressure requirement. If flow surges (a cause of pressure surges) are anticipated in the tank line, an external drain variation is recommended. The “Y” port in the subplate must be plugged when using an internal drain.

D41V* Flow Paths

Style Code	Description	No Solenoid/Operator Energized	Solenoid/Operator A Energized	Solenoid/Operator B Energized
B	Spring Offset	P→A and B→T	—	P→B and A→T
C	Spring Centered	Centered	P→A and B→T	P→B and A→T
D	Detented	Last Position Held	P→A and B→T	P→B and A→T
E	Spring Centered	Centered	—	P→B and A→T
F	Spring Offset, Shift to Center	P→A and B→T	—	Centered
H	Spring Offset	P→B and A→T	P→A and B→T	—
K	Spring Centered	Centered	P→A and B→T	—
M	Spring Offset, Shift to Center	P→B and A→T	Centered	—



Tank and Drain Line Surges

If several valves are piped with a common tank or drain line, flow surges in the line may cause an unexpected spool shift. Detent style valves are most susceptible to this. Separate tank and drain lines should be piped in installations where line surges are expected.

Loss of Pilot Pressure

Should a loss of pilot pressure occur, spring offset and spring centered valves will shift to the spring held position. No spring valves will stay in the last position held. If main hydraulic flow does simultaneously stop, machine actuators may continue to function in an undesirable manner or sequence.

Pilot Drain Characteristics

Pilot Pressure:

5 to 350 Bar (73 to 5000 PSI)
 6.9 Bar (100 PSI) for spool configurations 2, 7, 9 & 14

Direct pilot operated valves use the “X” and “Y” ports to supply pilot oil directly to the ends of the spool, providing spool shifting force. A block mounted on top of the valve body is internally cored to make the necessary connections. Thus when “X” is pressurized, “Y” is used as a drain; and when “Y” is pressurized, “X” becomes the drain.

Any back pressure in these lines when they are being used as a drain is additive to the pilot pressure requirement.

Internal Drain: On spring offset models, only the “X” port is pressurized, as the spring returns the spool to its at rest position. On these models, “Y” may be internally drained through the main tank passage in the valve.

Flow Path/Pilot Pressure

Style Code	Description	“X” & “Y” De-Pressurized	“X” Port Pressurized	“Y” Port Pressurized	Special Notes	Recommended Control Valve For Pilot Oil
B	Two Position Spring Offset	P→A, B→T	P→A, B→T	P→B, A→T	“X” Port may be pressurized to assist spring in returning spool to offset position (ext. only)	
C	Three Position Spring Centered	Center	P→A, B→T	P→B, A→T	Flow paths will be reversed on valves with tandem center (9) spool	
H	Two-Position Spring Offset	P→B, A→T	P→A, B→T	P→B, A→T	“Y” Port may be pressurized to assist spring in returning spool to offset position	

Subplate Mounting
NFPA D07, CETOP 7 & NG16



Recommended Mounting Surface

Surface must be flat within .102 mm (0.0004 inch) T.I.R and smooth within 812.8 micro-meters (32 micro-inch). Torque bolts to 135.6 Nm (100 ft-lbs).

For maximum valve reliability, adhere to the following installation information.

Mounting Position

Valve Type	Mounting Position
Detent (Solenoid)	Horizontal
Spring Offset	Unrestricted
Spring Centered	Unrestricted

Mounting Pattern — NFPA D07, CETOP 7 & NG16

Inch equivalents for millimeter dimensions are shown in (**)

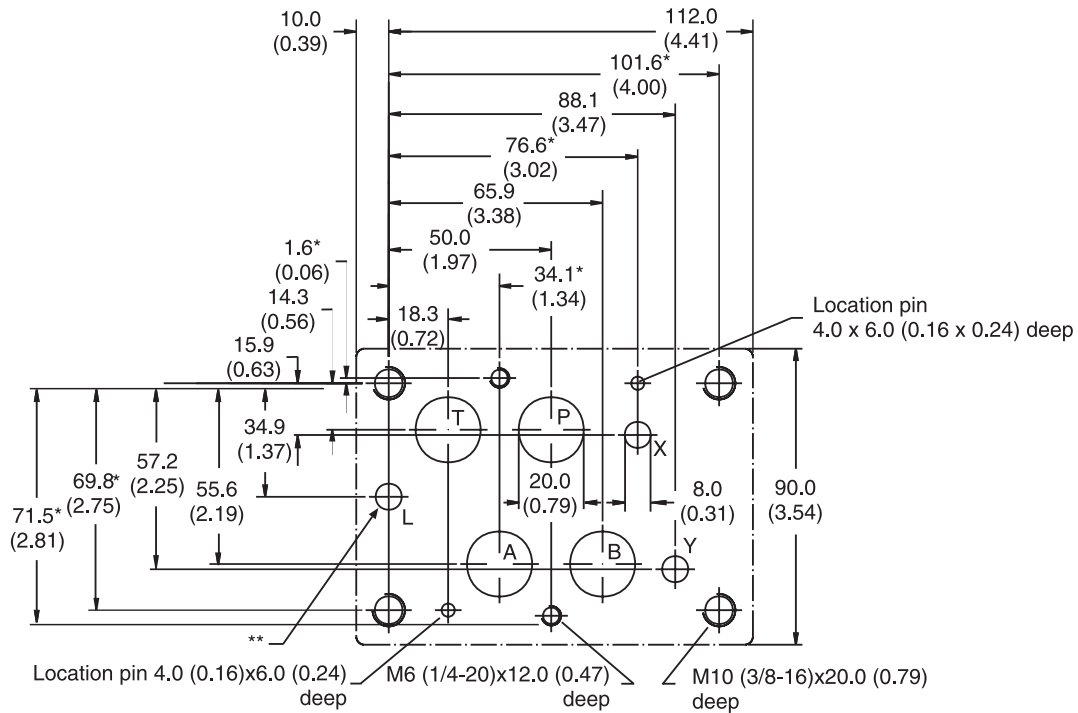

Note: With * marked dimensions ±0.1 mm. All other dimensions ±0.2mm.